



Installation Instructions

Part No. **3955** Product: Running Boards

Application: **Toyota Tacoma 2024 – Present**

Toyota 4 Runner 2025 - Present

Level of Difficulty: **1 2 3 4 5**

Professional Installation Time: 60 Min.

DIY Installation Time: 120 Min

REV 2 10/01/25

Hardware	Torque Aluminum	Torque Steel to Steel
M6 Bolt	3 ft-lbs.	14 ft-lbs.
M8 Bolt	7 ft-lbs.	35 ft-lbs.
M10 Bolt	16 ft-lbs.	64 ft-lbs.
M12 Bolt	28 ft-lbs.	112 ft-lbs.

ATTENTION: Use correct torque settings to avoid damaging the running boards and or mounting brackets. Failure to do so will void your warranty. If you have any questions, please contact our technical team at 1-866-717-6645

Attention: Please make sure that you have the latest instructions from **Romik.com**

QR Scan

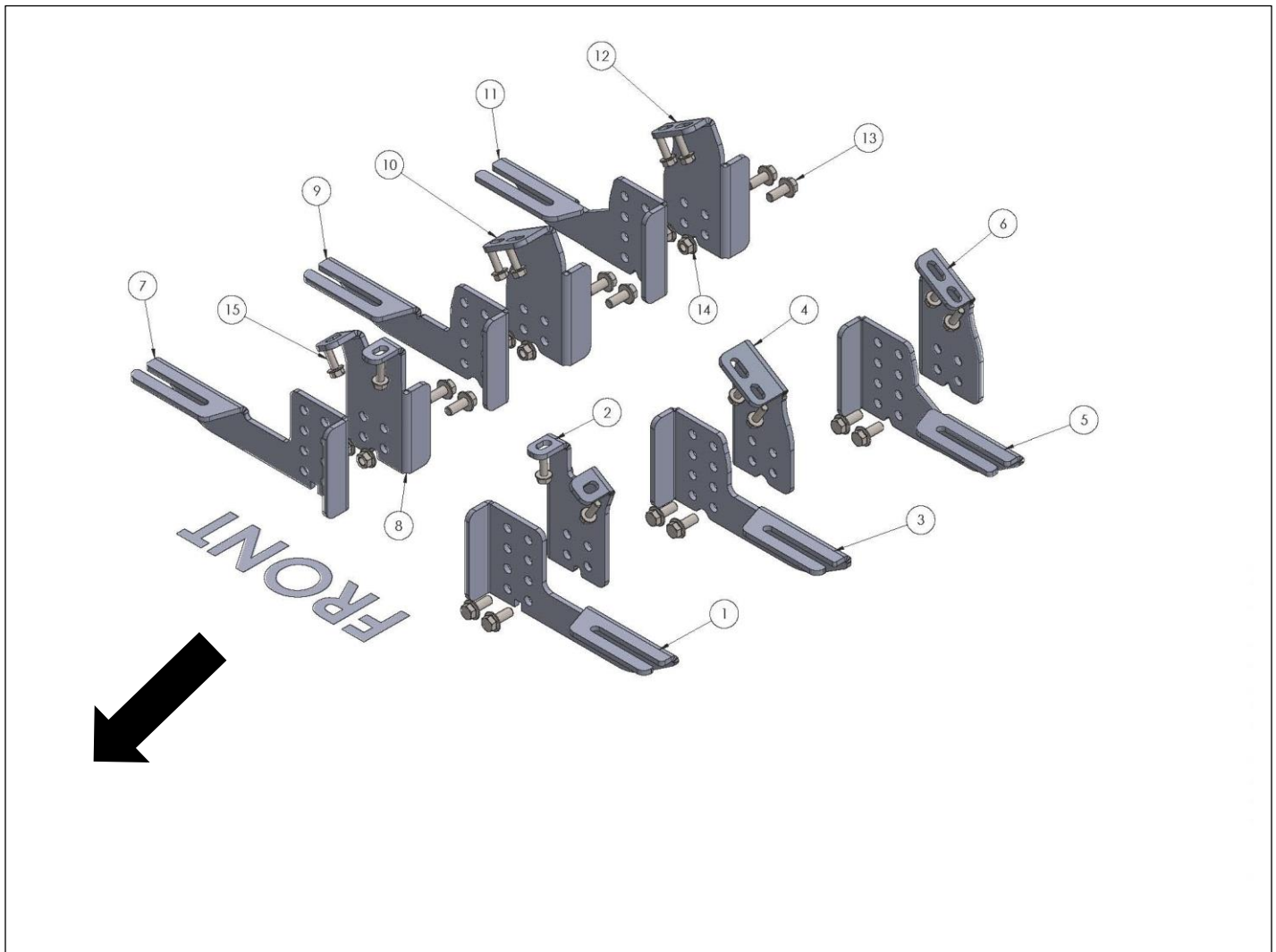

3955

1



**DRIVER/PASSENGER SIDE
FRONT SUPPORT
2 x QTY**

2

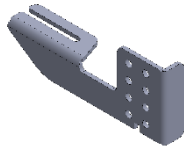

**DRIVER/PASSENGER SIDE
FRONT BRACKET
2 x QTY**

3



**DRIVER/PASSENGER SIDE
CENTER SUPPORT
2 x QTY**

4

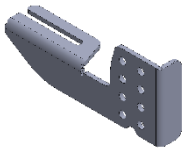

**DRIVER/PASSENGER SIDE
CENTER/FRONT BRACKET
2 x QTY**

5



**DRIVER/PASSENGER SIDE
REAR SUPPORT
2 x QTY**

6

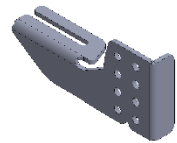

**DRIVER/PASSENGER SIDE
FRONT BRACKET
2 x QTY**

HARDWARE

7



**M10x25 HEX
FLANGE BOLT
12x**

8



**M10 HEX
FLANGE NUT
12x**

9



**M8x25 HEX
FLANGE BOLT
12x**

Installation Instructions “DRP” Bracket Kit

Thank you for choosing the Romik DRP System. This system allows you to adjust the brackets from 0 to 3-inch drop. If you ordered the **optional** DRP cover, you can customize them to match the desired height by cutting on the lines inside the cover. Please test before cutting, in many cases you will be able to tuck the cover behind the body of the vehicle without cutting. NOTE: **Blue Loctite is recommended on all metal parts**

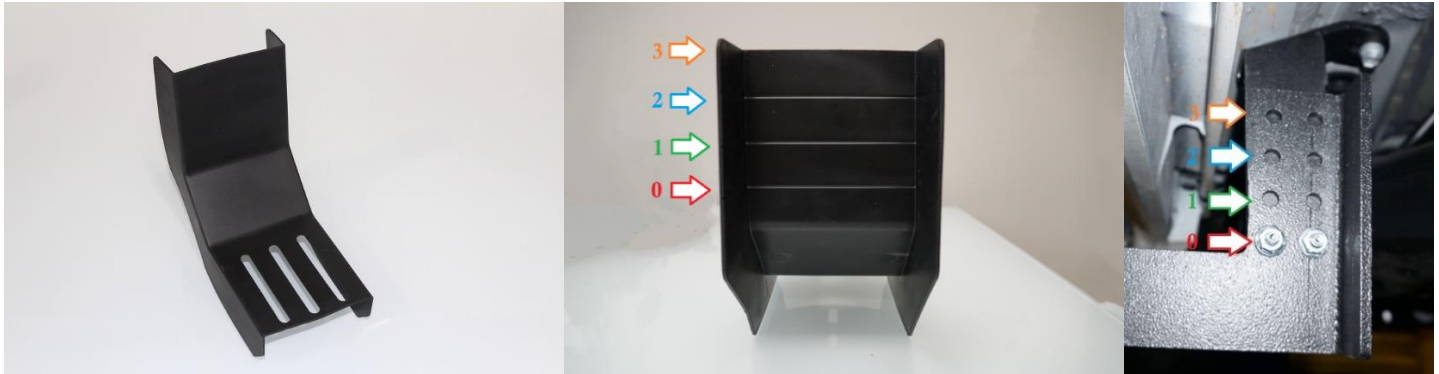

Step 1: Locate front mounting points Figure 1, remove factory bolts, dispose of them as we will be using supplied M8 hardware.



Step 2: Assemble DRP bracket and set to desired height. Position “A” is for Tacoma and 4 Runner highest level. Position Attach to vehicle, using supplied M8 and M10 hardware do not tighten figure 2.

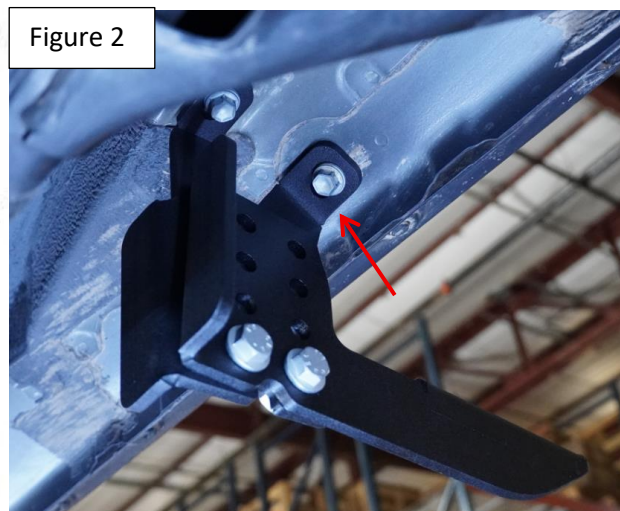
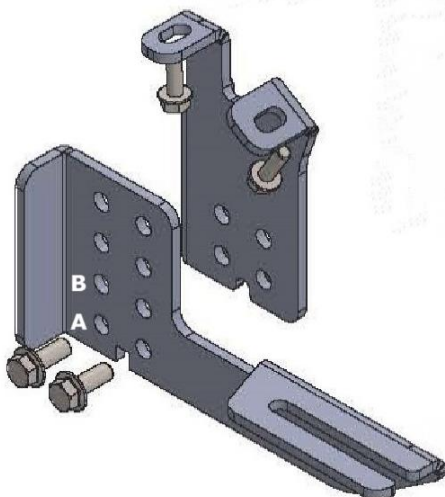

Installation Instructions "DRP" Bracket Kit

Step 3: Locate middle mounting points Figure 3, remove factory bolts, dispose of them as we will be using supplied M8 hardware.

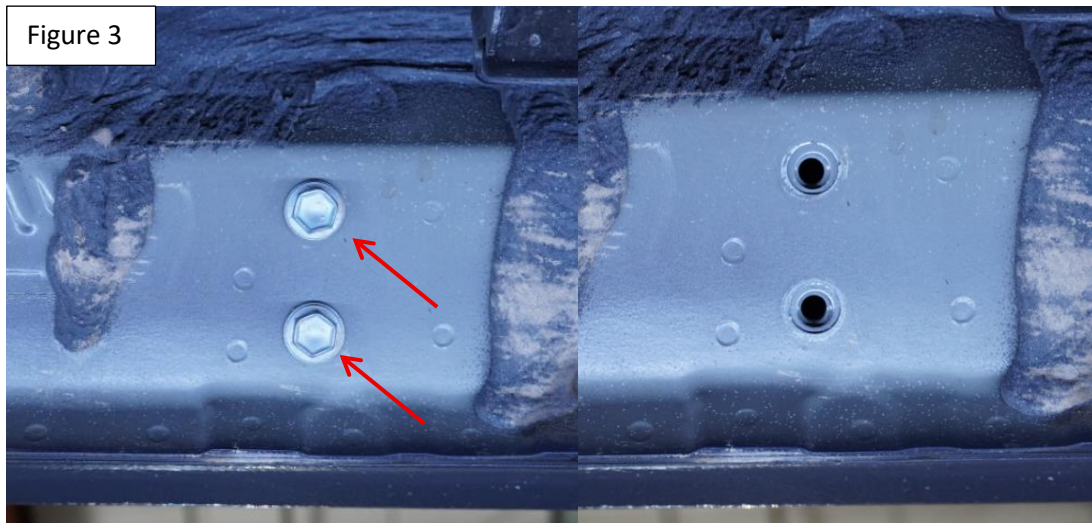

Step 4: Assemble DRP bracket and set to desired height. Position "A" is for Tacoma and 4 Runner highest level. Position Attach to vehicle, using supplied M8 and M10 hardware do not tighten figure 2.

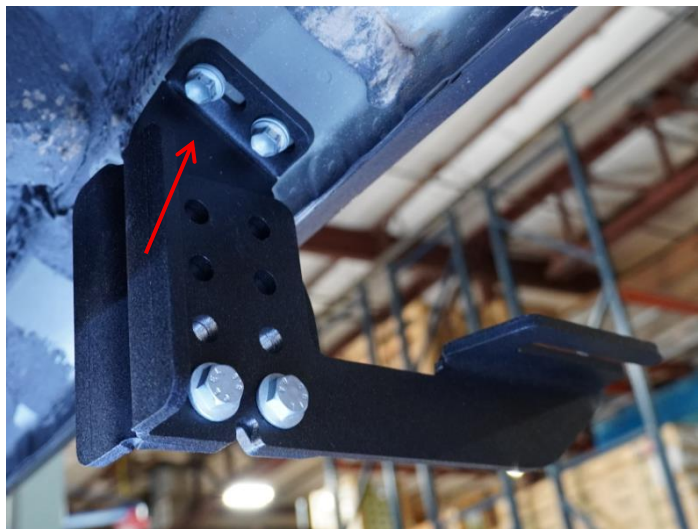
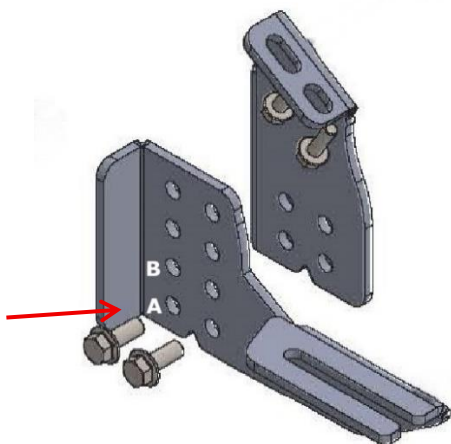

Step 5: Repeat steps #3 and #4



Installation Instructions “DRP” Bracket Kit

Step 6: Install DRP covers on brackets use slots to center the covers. **The DRP covers are placed between the running board and the bracket**

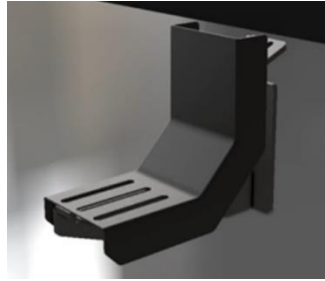

Torque M8 bolts to 35 lbs. Torque M10 bolts to 64 lbs proceed to last page of this manual for running board install instructions and torque values. Use of a level is recommended.

NOTE: DRP system is designed to assist you getting in and out of the vehicle. However the lower you place the brackets the lower the weight rating. For maximum weight capacity use DRP brackets at zero.

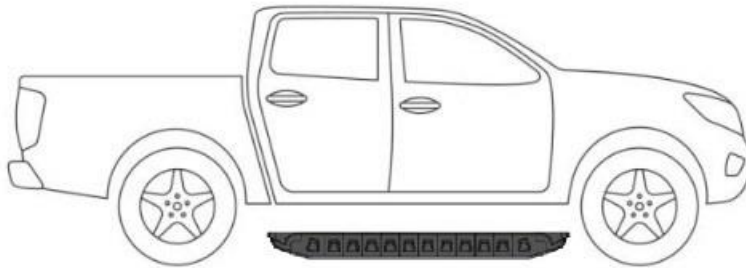

For Technical support please call our team at 1-866-717-6645 and one of our experts will assist you with this installation.

Thank you for choosing Romik.

Installation Instructions Running Boards

NOTE: Use of power tools will damage the bottom of the running board and void your warranty.

RAL/RB2/REC/RZR Running boards

Step 1: loosen the M8 hardware on back of the running boards.

Step 2: Slide running board onto brackets

Step 3: Tighten hardware to 7 ft lbs.



ROF/RPD/ROB Running boards

Step 1: Place clamping plate on top of running board as shown below. Make sure clamping plate sits correctly on running board surface.

Step 2: Install carriage bolts and plastic retaining clips as shown below.

Step 3: Install and tighten hardware to 7 ft lbs.

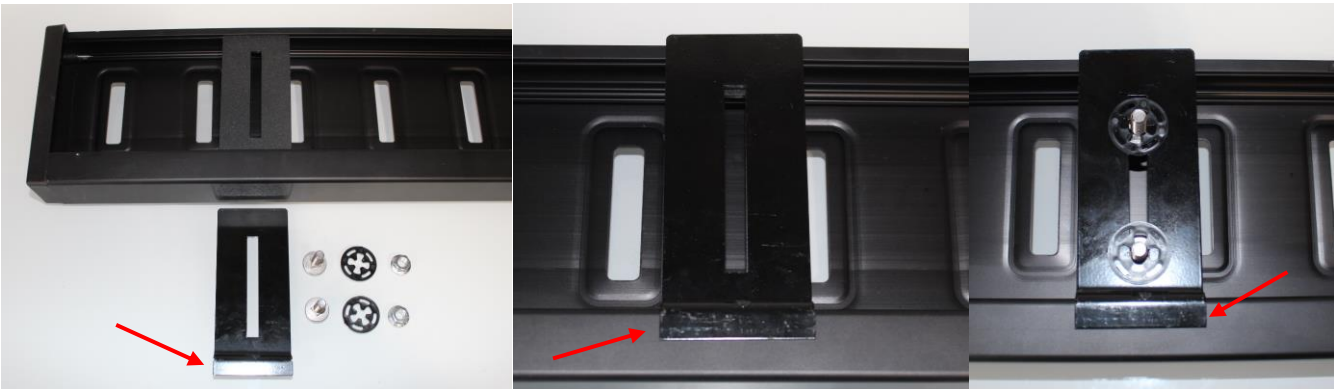

RPT-R Running boards

Step 1: Place the RPT-R running board on top of the mounting brackets. If you are using the optional DRP covers, make sure they are installed first.

Step 2: Slide the RPT-R clamp plates from inside the running board to its location. Wide section out green arrow / Narrow section towards the vehicle red arrow

Step 3: Repeat procedure on all mounting brackets

Step 4: Install and tighten hardware to 7 ft lbs.

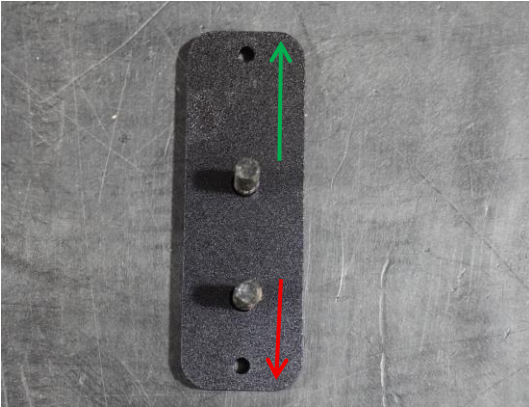

Product Registration and Warranty Information



- Register your Romik products at <https://romik.com/productregistration>
- Warranty information at <http://www.romik.com/warranty>

Cleaning and maintaining your Romik Running boards

Cleaning and maintaining your running boards is important, apply a light coat of a quality carnauba wax at least 2X per year. Wash often with mild soap and make sure to remove all soap residue. Many car automatic carwashes use a strong soap, make sure to use enough water to remove all residue.

For video instructions on how to clean your Romik products please click here <https://romik.com/cleaning>